

DOI: [10.20472/ES.2019.8.2.009](https://doi.org/10.20472/ES.2019.8.2.009)

## **EXPLOITATION OF PAYDAY LOAN USERS: FACT OR FICTION?**

*SILVIA SZILAGYIOVA*

### **Abstract:**

This paper explores the existence of different forms and underlying reasons for exploitation at the household level. The empirical analysis, based on data from the British Household Panel Survey (BHPS) collected to understand social and economic change in Britain, aims to identify the underlying factors behind mixed empirical evidence on the existence of exploitation among payday loan users. This paper goes beyond traditional economic explanations and focuses on factors defining conditional relative advantage exploitation leading to voluntary exploitation. The results suggest that, due to “acts of desperation”, current regulations on payday lending are powerless and cannot prevent households from being voluntarily exploited. In addition, the results show that an increased household financial burden and additional borrowing raise the likelihood of households taking risks in order to meet basic needs. The findings provide further insight into why current policy regulations fail to address the problem of payday lending.

### **Keywords:**

Payday loan; Voluntary exploitation; Absolutely disadvantaged households

**JEL Classification:** D14, G02, I31

### **Authors:**

SILVIA SZILAGYIOVA, York Business School, York St John University, United Kingdom, Email: [s.szilagyoiva@yorks.ac.uk](mailto:s.szilagyoiva@yorks.ac.uk)

### **Citation:**

SILVIA SZILAGYIOVA (2019). Exploitation of payday loan users: Fact or fiction? . International Journal of Economic Sciences, Vol. VIII(2), pp. 127-147., [10.20472/ES.2019.8.2.009](https://doi.org/10.20472/ES.2019.8.2.009)

## 1 Introduction and background

### 1.1 Misconception of Exploitation

There is an on-going debate on whether the payday loans are more harmful than beneficial to the users, mainly due to limited literature and mixed conclusions from empirical evidence on the link between payday loan access and financial well-being. Proponents such as Morgan and Strain (2008), Malzer (2011) and Morse (2011) claim that payday lending is a financial service that fills a gap in the market of short-term financial needs, which traditional lending institutions such as banks and financial providers are unable or unwilling to fill in. The roots of this argument are in limited options for payday loan customers who, without the access to payday loan providers, would have to reach for “black market moneylenders.” While this may be a valid argument, those who oppose payday loans (Brown and Taylor, 2008; Disney et al., 2008; Szilagyi, 2015) claim that this gap is filled by lenders via exploitative business practices through extremely high interest rates charged and targeted to low-income prospective users leading to a trap in form of rollover or repeated loans. Mayer (2003) proposes that the disagreement in literature on relationship between consumers and payday loan providers is due to the complexity of the relationship and interpretation of an “exploitative relationship”.

Exploitation and exploitative relationship are the conceptual elements of Marxism and its concept of a class (Marx, 1848). From Marxist point of view, exploitation is interpreted as a form of interdependence of the material interests of people (Wright, 2005). However, exploitation only occurs when three criteria are satisfied. Firstly, there must be an “*inverse interdependent welfare principle*”. This principle applies that the welfare of exploiters depends on material disadvantage of the exploited thus the interest of exploiters imposes harms on the exploited.

The second condition is the “*exclusion principle*”. By this principle, the interdependence of the welfare of exploiters and exploited is due to exclusion of the exploited from access to productive resources. The last condition of exploitative relationship is the existence of “*material advantage of exploiters*” (Bhaduri and Robinson, 1980). The material advantage is an outcome of exclusion of the exploited from access to productive resources. By this logic, exploitation can be interpreted as situation where inequalities in incomes lead to inequality in rights and dominance over productive resources. In general, it can be assumed that the relationship between the payday loan providers (exploiters) and payday loan users (exploited) satisfies all three criteria. The existence of interdependent welfare principle is present as profit of payday loan providers depends on material disadvantage of payday loan users in form of insufficient finances. In addition, the principle of exclusion is also satisfied as payday loan users use this service due to their limited or restricted access to other financial services. Also, material advantage can be seen as the main purpose of the existence of payday loan providers who have a definite material advantage over payday loan users.

Nevertheless, the application of exploitative relationship has limitations. As the empirical evidence shows (Del-Rio and Young, 2005; Malzer, 2011; Mishra and Fiddick, 2012) in some cases, not all of the three conditions are satisfied. This is the case when the second condition of “*exclusion principle*” is not present. As the evidence shows, some of the payday loan users option for payday loan even though they are not excluded from other forms of financial services.

As Wright (2005) explains, if all three principles of exploitation are not satisfied, the relationship is termed as “*nonexploitative economic oppression*”. In nonexploitative economic oppression, the welfare of the advantaged group at the expense of the disadvantaged group is still present, and relationship is based on the ownership and

dominance over economic resources. However, in nonexploitative oppression, the advantage from transferring the productive resources is restricted. Mayer explained this situation as situation where both, the provider of payday loan and consumer may benefit, supporting the findings of Morgan and Strain (2008), Malzer (2011) and Morse (2011). This is due to non-existence of exclusion from other forms of financing, thus the payday loan providers do not have a full control over economic resources.

The condition of satisfying all three principles is not always present and Mayer's argument of contrasting opinions on payday loan services can be explained by different interpretations of exploitation. In particular, proponents draw on neo-Marxist definition of exploitation, according to which exploitation occurs when the "working class" is alienated from the factors of production (Wright, 1979). In neo-Marxists interpretation of exploitation, the working class is exploited especially in a capitalist economy. This interpretation can be applied to relationship between payday loan providers and consumers. The service payday loan companies provide is a short-term form of "capital" which is used in relation to a broader understanding of the "factors of production". In such instances, the low-income clients with poor credit rating and limited opportunities for financial support are indicative of those that are understood as the "working classes", which in capitalistic economy represent those at the lower economic stratum of society. The term 'social class' draws from neo-Weberian and neo-Marxist understanding which focuses on processes of opportunity hoarding or social closure in market relations and neo-Marxist approach that focuses on relations of economic production, through processes of ownership and labour, domination and exploitation (Muntaner et al., 2000). Therefore when consumer from lower social class (low-income client) is excluded from capital (understood as a factor of production) and payday loan companies provide the short-term "fix", this situation can be beneficial for both parts.

The opponents of payday loans draw from a neoclassical economics view, which agrees with the existence of exploitation in imperfect competition. According to neoclassical view, in imperfect competition, all consumers are exploited due to restricted output in the market and higher prices while in perfect competition, not all consumers are exploited. The limitation is that, according to neoclassical assumption all payday loan clients are exploited. This is in contrast to the empirical evidence. The interpretation is too broad and does not distinguish between social classes.

While neo-Marxist and neoclassical explanation of exploitation can be seen as extreme cases, Mayer (2003) introduces "*sufficiency exploitation*" and "*relative advantage exploitation*" that helps to describe the relationship between consumer and provider of payday loan in more applicable manner. Sufficiency exploitation draws on neo-Marxist exploitation but in less restrictive way. It relates to situation where a low-income consumer, excluded from other forms of credit, seeking for a short-term credit engages in a relationship with provider who is willing to supply the short-term credit. Sufficiency exploitation therefore exists if the consumer's financial situation is better after taking the loan compared to the situation if loan was not available. The basis of sufficiency exploitation is in an absolute disadvantage of a certain group. The absolute disadvantage is understood as an absolute exclusion from other forms of credit, which mostly applies to the low-income consumers. The sufficiency exploitation only exists if consumers without absolute disadvantage, thus consumers whose income is higher and are therefore not excluded from other forms of credit, do not use payday loans. If the opposite applies and both, consumers with absolute disadvantage and consumers without absolute disadvantage use payday loans equally, the sufficiency exploitation does not exist and payday loan is understood as an expensive financial service. In contrast to neo-Marxist definition of exploitation that strictly applies only to consumers from lower social class, Mayer's approach to exploitation is more flexible and encounters the engagement of consumers from middle backgrounds. As the evidence (Morgan and Strain, 2008; Malzer, 2011; Morse, 2011) shows, even though the majority of payday loans consumers are consumers with absolute disadvantage, there are also consumers without absolute disadvantage who also use the service. Therefore, the applicability of sufficiency exploitation may not be straightforward in practice.

In contrast to sufficiency exploitation, the relative advantage exploitation relates to rollover and repeated loans, which is the main argument of payday loan opponents but is not related to neoclassical interpretation. It relates to the conflict when consumer's intention is to take a short-term loan but ends up extending payday loan or repeats borrowing. The 'relative' part of this type of exploitation is the relative, often only very short-term, improvement of financial situation of payday loan consumer. Payday loan providers charge high interest rates expressed as annual interest rate which when calculated to a few weeks loan, does not represent a significant financial burden to the consumer – relative financial improvement. However, in the UK, 28 per cent of payday loans are rollover loans (Edmonds, 2014). Short-term loans converted into medium-term loans are often an outcome of a business practice of payday loan providers who encourage consumers to rollover or attract consumers who are more likely to extend the loan. On the other hand, the evidence shows that not all short-term loans are converted into rollovers thus relative advantage exploitation, as proposed by Mayer (2003) cannot be demonstrated. The discouragement from rollover is more evident in cases of consumers without absolute disadvantage while relative advantage exploitation is more likely to occur in cases of consumers with absolute disadvantage. There is no distinction between consumers with absolute disadvantage and consumers without absolute disadvantage in Mayer's proposed relative advantage exploitation. Therefore, if a consumer (with or without absolute disadvantage) uses a payday loan only for a short-term as initially intended, it is a win-lose situation for the consumer. The payday loan provider loses, as the main income of payday loan providers (around 50 per cent of their revenue) is from rollovers and late payments rather than high interest rates (Edmonds, 2014). This situation supports the argument of proponents. On the other hand, if consumers get trapped into rollover (this is more likely to happen to consumer with absolute disadvantage), it is a win-lose situation for the payday loan provider, which in turn supports the argument of opponents to payday loans.

Nevertheless, relative advantage exploitation does occur, but in more isolated situations defined by specific factors and can be therefore presented as "*conditional relative advantage exploitation*". The distinction between consumers with absolute disadvantage and without absolute disadvantage seems to be crucial for the existence of conditional relative advantage exploitation. The unknown factors that underpin the existence of exploitation in isolated groups go beyond discussed types of exploitation and are related to factors that define consumers with absolute disadvantage.

It is suggested that consumers' irrational behaviour, structural changes in the economy and perhaps financial literacy may be the underlying factors of the existence of conditional relative advantage exploitation.

## 1.2 *Rationally irrational Consumer's behaviour*

Neoclassical economic theory on consumer behaviour, proposed that consumer's behaviour could be defined by the rationality axiom (Bernheim, 1986). The rationality axiom introduces an economically rational consumer who maximizes his utility. Broader interpretation of rationality axiom is that pursuit of utility is only done by rational economic behaviour and everything else is irrational. In neoclassical view, consumers make rational choices that lead to maximizing their utility (Davidson, 1996). If applied to financial decisions, consumers are expected to act rationally when deciding about type and size of credit they use. Neoclassical interpretation of consumer behaviour contradicts with observed behaviour of payday loan consumers particularly consumers with absolute disadvantage. As Keynes (1936) stated, [it is a] "*human nature that large proportion of our purposive activities depend on spontaneous optimism rather than on mathematical expectation.*" (Keynes, 1936; p.161).

Through statements such as this Keynes appears to object to the neoclassical conditions that underlines consumer's rational behaviour in the utility maximizing model. As he explains, our actions towards consumption are driven not only by objective factors but also

predominantly by subjective factors, which tend to be underpinned by our emotional state. In his discussion, Keynes introduces the psychological law of consumption where increase in income leads to increase in consumption, but the increase is not proportional. While in the long-term the increase in consumption may be proportional to the increase in income, in the short-term, consumption tends to increase at smaller proportion. As he explains, the discrepancy between increased income and consumption in the short-term is driven by habits:

*“For a man’s habitual standard of life usually has the first claim on his income, and he is apt to save the difference which discovers itself between his actual income and the expense of his habitual standard; or, if he does adjust his expenditure to changes in his income, he will over short periods do so imperfectly”* (Keynes, 1936; p. 97).

Keynes’ explanation of how habits form imperfect decisions in short-term consumption behaviour may be used to explain behaviour of payday loan consumers, when used in reverse. By this logic, when consumers experience a decrease in their actual income, their consumption decreases but the decrease may not be proportional in the short-term due to habits leading to imperfect decisions. This can also be used as an explanation of why consumers without an absolute disadvantage option for payday loans. If consumers without absolute disadvantage experience a decrease in the actual income, they may use payday loans in the short-term to cover the gap between the previous and actual income. Keynes’ assumption of proportional change in the long-term, may also explain why relative exploitation (thus rollover debt) does not occur in situation when consumers without an absolute disadvantage option for a payday loan. Consumers without an absolute disadvantage can adjust their habits to the level of new, lower, income in the long-term when their consumption behaviour returns into neoclassical utility maximization model.

The adjustment of habits to the lower level of income may not be possible for consumers with absolute disadvantage especially if their ‘habits’ are synonymous to basic needs of survival such as utility bills, rent and food. Relative advantage exploitation, thus rollover debt, cannot be avoided. The irrational behaviour (in neoclassical view) of consumer with absolute disadvantage, whose behaviour in capitalistic economy can be described as survival decisions, is what Keynes (1936) described as a result of animal spirits. Keynes explains the concept of animal spirits as *“a spontaneous urge to action rather than inaction, and not as the outcome of a weighted average of quantitative benefits multiplied by quantitative probabilities”* (Keynes, 1936; pp. 161-162). By this logic, consumers with absolute disadvantage act spontaneously, driven by the urge to solve their short-term discrepancy in income and expenses, without careful consideration of consequences in the long-term. However, due to inability to adjust their habits to the new, lower income in the long-term, they get trapped in rollovers. While neoclassical view refuses the role of psychological factors in decision-making, Keynes clearly placed extreme importance on psychological processes rather than ‘economic calculus’. Keynes’ view on the role of psychological processes in decision-making provides the base for understanding why consumers with absolute disadvantage option for payday loan. It is however unclear why specifically this group fails to consider the long-term financial consequences that lead to relative advantage exploitation.

Traditional economic theories can hardly provide the answer as they view consumer as a ‘standardized economic agent’. The discrepancy in exploitation proves that standardization leads to limitations and focus should be towards better explanation of very specific external factors that affect psychological processes in decision making. In contrast to traditional economics theories, behavioural economics view human behaviour as more complex and not entirely rational processes. The concept of ‘bounded rationality’ introduced by Simon (1982) suggests that human minds must be understood relative to the environment in which they evolved. From this perspective, decision-making processes of payday loan consumers with absolute disadvantage may be explained by the long-term external factors that define the environment in which they have been evolving. There are restrictions to human

information processing due to lack of knowledge as well as computational capacities (Simon, 1982). If these factors define environment of payday loan consumers with absolute disadvantage, they may as well provide an answer to why this specific group gets trapped in rollovers and repeated loans while consumers without absolute disadvantage tend to escape it.

As mentioned, behavioural economics view decisions-making processes in a contrasting way with emphasis on distinction between simple economic decisions and more complex economic decisions. It suggests that humans tend to make better simple economic decisions when emphasis is based on reasoning thus logical processing of available information (Morris, 1995). However, more complex decisions involve more information and logical processing becomes more complex as consumers become overwhelmed by too many information and option to make a decision based on their emotions. This is in line with Keynes' animal spirit behaviour, but while Keynes proposed that emotional state affects the decisions, behaviour economics takes it further and considers that more complex economic decisions are subject to constrains including intellectual capacities. McCarthy (2011) investigated the determinants of financial difficulties, concluding that behavioural factors such as an individual's capacity for self-control, planning and patience play important role.

Nevertheless, consumers' behavioral biases and cognitive limitations change the optimal response to traditional market failures that are often addressed by information provision or disclosure: to mitigate asymmetric information, to reduce search costs and limit market power. Mandated information provision may be an ineffective remedy if consumers either do not understand the information or believe that it is not relevant to their decision-making. Transparent disclosure of late fees and interest rates might not change their behavior (Campbell et al., 2011). Since payday loans are subject of more complex economic decisions, their transparent disclosure of late fees and interest rates involve Government interventions. Government's regulations towards solving the problem with payday loan providers and exploitation seem to follow neoclassical approach to rational behaviour where underlining condition of rational consumer behaviour lies in "perfect information".

*"The Disclosure Regulations require pre-contractual information to be given in good time before the borrower enters into the agreement. The information must be clear and easily legible, and the borrower must be able to take it away to consider it and to compare it with other offers if they wish. In most cases the information must be provided in a standard format, the Pre-contract Credit Information form, known as the 'SECCI', to aid comparability and consumer understanding."* (Gov, 2014; p.15)

It is clear that regulations of payday loans follow the view that clear and sufficient information will encourage consumers to behave more rationally and decisions will be driven by reason rather than emotions. The effectiveness of sufficient and clear information is limited by constrains of more complex economic decisions, which payday loans are, including intellectual capacities of consumers. If the avoidance of relative advantage exploitation was underpinned by sufficient information, consumers with absolute disadvantage would not be exposed to exploitation. The regulations on information provided by payday loan companies may have desirable effect on consumers without absolute disadvantage who, based on "perfect" information, act more rationally and avoid being trapped in rollovers. In case of consumers with absolute disadvantage, the ability to process and compute information plays more crucial role than the amount of information available. It is however unclear, why consumers with absolute disadvantage fail to act more rationally and end up being exploited. This leads to previously mentioned Simon's (1982) suggestion that human minds must be understood relative to the environment in which they evolved. Disney and Gathergood (2006) found the link between financial literacy and consumer credit portfolios, concluding that households with poor financial literacy hold higher shares of high cost credit and engage in behaviour that might lead to financial distress. However, the poor financial literacy is investigated as a given factor and its existence has not been fully explained. In contrast to their findings that are based on the U.S sample, the results of the survey by Livingstone and

Lunt (1992) show that the level of education does not play a significant role in the UK. This suggests that while financial literacy, or education may play a role, it is not the underpinned reason that could explain why consumers with absolute disadvantage are exploited.

### *1.3 The roots of rationally irrational behaviour of consumers with absolute disadvantage*

Since the evolvement of a human mind begins at a very early age, it suggests that a household environment may be the most influencing factor. There is a well-established argument that outcomes in childhood are crucial for adult's social and economic success (Carneiro and Heckman, 2003). As Carneiro and Heckman (2003) explain, individual scholastic ability is influenced by long-term family and environmental factors, which are in turn produced by the long-term permanent income of families. Their argument is supported by evidence on developmental deficit of low-income children and its long-term social and economic consequences (Blanden et al., 2007; Feinstein, 2000; Gregg and Machin, 1998). Discrepancy in abilities between children from low-income households and middle-income households may explain the discrepancy in processing and computing information as adults and existence of exploitation.

It is a vicious cycle, especially in countries such as the UK with strong links between individual and parental earnings measured as intergenerational earnings elasticity being 0.5 (D'Addio, 2007). This level of elasticity suggests a great persistence of earnings across generations, thus lower level of intergenerational earnings mobility. More recent evidence shows that in the UK, education as such, is not a direct proxy for intergenerational economic mobility. The underpinning factor is parental income and early unemployment experience with long-lasting impact (Gregg et al., 2015).

Therefore, in the UK, children from low-income households are more likely to remain in low-income scale in their adult age, creating a developmental deficit for their next generation. The scale of this issue is great as new evidence on poverty in the UK published by ONS (2015) shows that 60 per cent of single parent households with dependent child experienced poverty for two or more years in the period between 2010 and 2013. As evidence shows, the single parent households are 50 per cent more likely to experience poverty than households with two or more adults. The poverty experienced by lower-income households often leads to financial distress, which has increased significantly in the UK over the years, especially after the financial crisis in 2008.

Financial distress can be defined as a condition to where individuals cannot or have difficulties with debt repayment (McCarthy, 2011). The underpinned reasons that are often investigated as drivers of households' financial distress include marital status, age, job security, source and level of household income (Giannetti et al., 2014). Brown and Taylor (2008) investigated the link between the income and credit portfolio among UK consumers. Their results show that significant role is played by the actual source of income, specifically whether the source of main income is wage or government benefit system. Their results can be interpreted as households, with main income from government benefit system (consumers with absolute disadvantage) are more likely to experience financial distress than households not dependent on government benefit system (consumers without absolute disadvantage). Other studies, using the UK sample, show that also socio-demographic background such as age plays important role, highlighting the fact that younger age individuals possess higher risk of over-indebtedness (Bridges and Disney, 2004; Livingstone and Lunt, 1992). The study on financial distress among British households that considers age as important factor has been done by Del-Río and Young (2005) and shows that from 1995 to 2000 there was an increase in indebtedness among the young individuals, especially single parents, which led to their financial distress. Although the results are interesting, the source of income, found by Brown and Taylor as important factor, has been omitted. In relation to age and financial distress, low or zero precautionary savings are found

to be the underpinned factors for experiencing financial distress of young individuals (Benito, 2006).

The number of households experiencing financial distress in the UK is increasing with implications for the individuals involved as well as for the financial system in terms of costs involved. In this context it is vital to understand why consumers with absolute disadvantage are more likely to be exploited by payday loan providers, so that appropriate means of preventing exploitation of this group can be devised.

#### *1.4 Profile of UK payday loans consumers*

In the UK, the majority of payday loans consumers belong to a low-income group with income lower than £15,499 that is below the UK average of £24,492. According to the survey by Consumer Focus more than 50 per cent of interviewed consumers in South East, London, North England and Scotland have been in a substantial debt at the time taking the payday loan (Burton, 2010). While some of the consumers described their experience with payday loans as positive, consumers who were already in financial difficulty reported negative experience related to the rollover debts as a consequence. Even though most of the respondents were from low-income group (consumers with absolute disadvantage), not all of payday loan users have experienced worsening of the financial situation as a consequence of taking the payday loan. Existence of a dispute in the effect of payday loans on households' financial distress is due to a relative advantage exploitation occurring in isolated groups – conditional relative advantage exploitation. The survey also uncovers that the main factor of affecting the decision-making is the existence of gap between actual income and level of costs when alternative solutions such as overdrafts and credit cards are unavailable due to poor credit rating or exhausted use of these resources. An observable pattern of irrational behaviour of borrowers can be identified from the behaviour of respondents. As respondents in the survey admitted, the problem of repaying the loan accelerated by taking more or higher loan than they would usually do. Significant number of respondents also admitted problems with managing money and had a history of large debts.

## *2 Methodology*

### *2.1 Data*

The primary data source for this study comes from the British Household Panel Survey (BHPS, 2014) which was conducted by the Institute for Social and Economic Research (ISER) at the University of Essex. To date, eighteen waves of the survey have been collected from 1991-2009. The supplement contains a nationally representative sample of 5,500 households and 10,300 individuals drawn from 250 areas of Great Britain, 1,500 households in each of Scotland and Wales and 2,000 households in Northern Ireland, making the panel suitable for UK-wide research.

The data were collected by questionnaires and interviews for the purpose of a multi-purpose study focused on understanding of social and economic change at the individual and household level in Britain, identification, modelling and forecasting such changes, their causes and consequences in relation to a range of socio-economic variables. Figure 1 shows the distribution of survey sample used in this study together with geographic spread of payday loan clients with a high concentration of payday loan debt in the North East and West Midlands and the gross disposable household income (ONS, 2014)

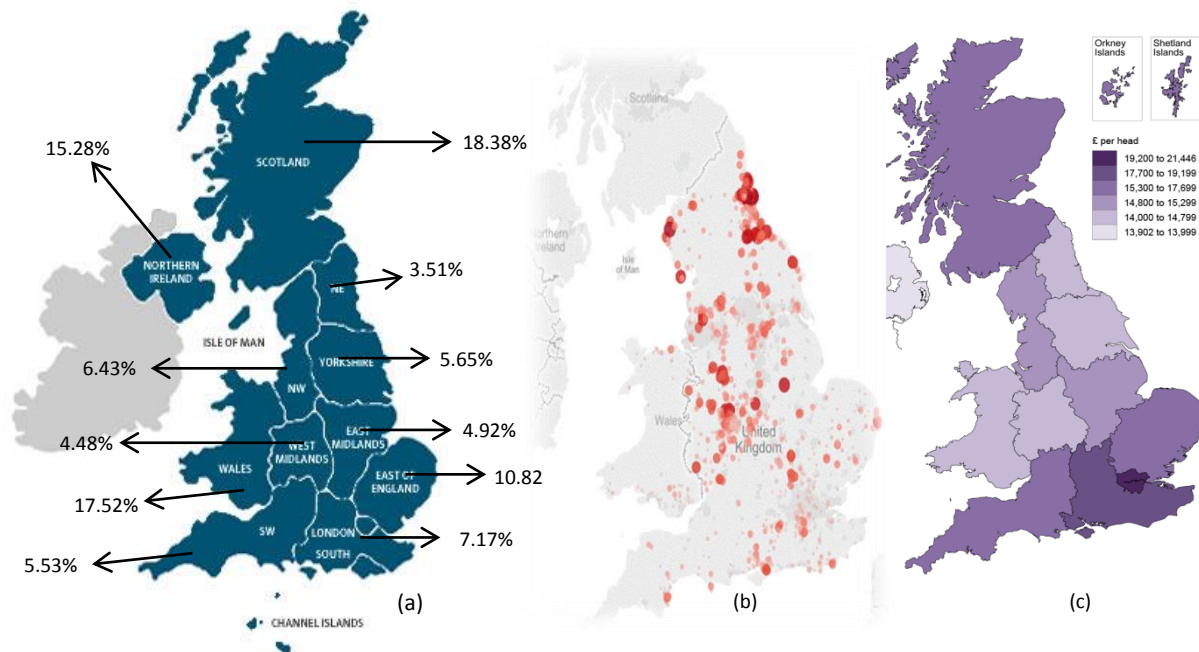
**Figure 1** (a) Sampling distribution (b) geographic spread of payday loan clients (c) regional Gross Disposable Household Income

As data suggest, the payday loan companies are strategically concentrated in areas with lower disposable household income. The concentration is very tactical since majority of households in these areas represent consumers with absolute disadvantage, thus group with limited options for alternative financial solutions such as overdrafts and credit cards due to poor credit rating or exhausted use of these resources. As proposed in the literature, the main source of income of payday loan providers comes from rollovers and inability to repay on time. Creation of exploitative relationship between payday loan provider and consumer is therefore the proxy of provider's income. Naturally, building the exploitative relationship is part of payday loans business model in order to achieve desirable income. To build this exploitative relationship, targeting consumers with absolute disadvantage is essential, but consumers without absolute advantage are not excluded from using the payday loans, perhaps due to low, but yet existing, probability that they might also get trapped in rollovers. The mixture of consumers from both groups (with and without absolute advantage) leads to discrepancy in existing evidence on the effect of payday loan on consumers' financial distress, disagreement in the literature and ineffective government interventions as a consequence. In order to tackle the problem of exploited consumers, it is essential to distinguish these two groups and provide more insight into underpinning factors defining behaviour of consumers with absolute disadvantage.

## 2.2 Profile of respondents

In respect with Simon's (1982) suggestion that human minds must be understood relative to the environment in which they evolved, the investigation begins with looking at the family background of the respondents since this has a direct effect on the adult's economic outcomes (Burgess et al., 2001). The majority of respondents in the sample are either single parents or both parents with dependent child (8 years old on average) and 97% attend state school and only 3% private school. Difficult financial environment may affect the relationship between parents and child. According to Hammaker (2010) difficult financial situation or financial distress in families correlates significantly with increased abuse of children and violence within families. From the survey, 26% of parents admitted that they spanks or slaps their child and at the same time 24% of these respondents described their financial situation from quite difficult or very difficult (Fig 2).

**Figure 2** Financial situation

financial situation	Freq.	Percent
proxy and or phone	231	1.60
don't know	22	0.15
living comfortably	4,002	27.76
doing alright	5,367	37.22
just abt getting by	3,640	25.24
finding it quite difficult	827	5.74
finding it very difficult	330	2.29
Total	14,419	100.00

In the sample, the average annual household income with at least one person employed is £21534.7 (Fig 3a) compared to an average annual household with only benefit income of £5182.5 (Fig 3b). The average income level in both groups is below the UK's national average. Group with an average annual income £21534.7 is less likely to be excluded from other forms of credit represents consumers without absolute disadvantage. The likelihood of group with an average annual income of £5182.5 being excluded from other forms of credit it extremely high and represents consumers with absolute disadvantage.

**Figure 3** Annual income of household

Variable	Obs	Mean	Std. Dev.	(a)
rfighhl	8144	21534.7	25824.94	
Variable	Obs	Mean	Std. Dev.	(b)
rfighyb	8144	5182.508	5964.101	

As discussed previously, a typical profile of payday loan customer is a low income individual, with low or zero level of savings and limited or exhausted options for additional financial support (bank loans, credit cards, overdrafts). Figure 4 shows that most of the respondents (61%) have no savings. While lack of savings is identified in both groups, there is a strong positive correlation (0.7403) between financial situation of the respondents and their approach to savings, showing that households with absolute disadvantage are less likely to save than households without absolute disadvantage.

**Figure 4** Households' savings

saves from current income	Freq.	Percent
proxy and or phone	231	1.60
refused	179	1.24
don't know	5	0.03
yes	5,489	38.07
no	8,515	59.05
Total	14,419	100.00

As Benito (2006) proposed, the households with low or zero savings and difficult financial situation may be more likely under the pressure of reducing non-durable consumption or are exposed to worsening of the financial situation in the future. From the sample of where 21.11% of households already have repayments on hire purchase or loans, 32.9% of households needed extra borrowing to cover housing payments over the year compared to 67.06% of households without requirement of extra borrowing (Fig 5). On the other hand 83.5% of households needed to cut back on their non-durable consumption (Fig 6).

**Figure 6** Financial situation required extra borrowing

housing payments required borrowing	Freq.	Percent
missing or wild	2	0.02
inapplicable	7,185	88.22
proxy and or phone	538	6.61
yes	138	1.69
no	281	3.45
Total	8,144	100.00

**Figure 5** Cutbacks on non-durable

housing payments required cutbacks	Freq.	Percent
missing or wild	2	0.02
inapplicable	7,185	88.22
proxy and or phone	538	6.61
yes	350	4.30
no	69	0.85
Total	8,144	100.00

Worsening of the financial situation due to low savings or unexpected decrease in income is also found in the sample. In the sample, 56.19% stated that their financial situation has changed over the year and 56.64% found themselves in worse financial situation then in a previous year mainly due to increased expences and lower earnings. Only 28.27% consider their financial situation being better then in the previous year mainly due to increased earnings (Fig 7).

**Figure 7** Changes in financial situation

why financial situation changed	Freq.	Percent
missing or wild	15	0.10
inapplicable	6,317	43.81
proxy and or phone	965	6.69
refused	1	0.01
not answered	19	0.13
earnings increased	1,485	10.30
benefits increased	191	1.32
invest't income inc	50	0.35
less expenses	269	1.87
windfall payment	94	0.65
earnings decreased	830	5.76
benefits reduced	67	0.46
invest't income dec	109	0.76
more expenses	3,100	21.50
one off expenditure	60	0.42
earn more:more expens	7	0.05
earn more:less benft	5	0.03
more benft:more expens	5	0.03
less svgs:same std livg	41	0.28
good management	160	1.11
better off:other reason	296	2.05
worse off:other reason	329	2.28
nthr better/worse:reason	1	0.01
other	3	0.02
Total	14,419	100.00

In uncertain situations it is natural that humans prefer risk aversion. Although it has been proven that indebetness might lead to psychological distress such as depression or anxiety (Brown et al.2005; Bridges and Disney, 2005), psychological research also indicates that it is the psychological distress that encourages individuals to risk taking (Pezza and Baumeister, 1996). From the sample, 62.44% have tendency to take higher risk (Fig 8) while only 7.89% experience psychological distress (Fig 9) in form of depression or anxiety. Although only minority of respondents experience psychological distress, a positive correlation (0.5116) is found between respondents with psychological distress and higher likelihood of taking risk.

**Figure 9** Attitude towards taking risk

generally takes risks	Freq.	Percent
missing	733	5.08
proxy and or phone	965	6.69
don't know	7	0.05
won't take risks	680	4.72
2	588	4.08
3	1,148	7.96
4	1,296	8.99
5	2,441	16.93
6	2,082	14.44
7	2,180	15.12
8	1,390	9.64
9	415	2.88
ready to take risks	494	3.43
<b>Total</b>	<b>14,419</b>	<b>100</b>

**Figure 8** Psychological Distress

health problems: anxiety, depression, et	Freq.	Percent
proxy and or phone not mentioned	<b>734</b>	<b>5.09</b>
anxiety, depression	<b>12,547</b>	<b>87.02</b>
	<b>1,138</b>	<b>7.89</b>
<b>Total</b>	<b>14,419</b>	<b>100.00</b>

It is important to note that a number of respondents already have some kind of loan therefore increased costs of living and reduced household income due to repayments, subscribed for worsening of their financial situation. However, worsening of financial situation does not necessary lead to household burden or financial distress. Below, Figure 10, shows the respondents' perception to whether repayments on loans cause a financial distress in their household. From the sample, most of the households (55%) with loan do not experience financial distress while 45% households recognize repayments as a pressure on households' budget in form of a heavy burden (11%) or medium burden (34%).

**Figure 10** Household financial

repayments a burden on household	Freq.	Percent
missing or wild	56	0.69
inapplicable	5,831	71.60
proxy and or phone	538	6.61
heavy burden	188	2.31
somewhat of burden	582	7.15
not a problem	949	11.65
<b>Total</b>	<b>8,144</b>	<b>100.00</b>

The above results indicate a possible existence of the link between households' financial situation, underpinned by the level of income, basic expenses, the approach to savings, repayments of loans and financial distress. To test whether these assumptions are correct, in respect to the nature of data, a nonparametric Spearman rank-order correlation coefficient is computed on the ranks and average ranks (Conover, 1999), to measure the strength and direction of association between selected variables. The significance is calculated using the approximation:

$$p = 2 \times \text{ttail}(n - 2, |\hat{p}| \sqrt{n - 2} / \sqrt{1 - \hat{p}^2}) \tag{1}$$

Given for any two pairs of ranks  $(x_i, y_i)$  and  $(x_j, y_j)$  of one variable pair  $1 \leq i, j \leq n$  where  $n$  is the number of observations defined as concordant only if  $(x_i - x_j)(y_i - y_j) > 0$ , and discordant if  $(x_i - x_j)(y_i - y_j) < 0$ . Results from Spearman correlation coefficient (Fig 11) also include statistical significance tests in order to reject insignificant relationships from further analysis.

**Figure 11** Spearman correlation coefficients

	rxpfood	rxphsdf	rxphsd2	rxphsd1	rxphpdf	rriska
rxpfood	1.0000					
rxphsdf	0.0938* 0.0000	1.0000				
rxphsd2	-0.2985* 0.0000	-0.1341* 0.0000	1.0000			
rxphsd1	-0.2982* 0.0000	-0.1341* 0.0000	0.9998* 0.0000	1.0000		
rxphpdf	-0.0022 0.8462	0.1545* 0.0000	0.2741* 0.0000	0.2739* 0.0000	1.0000	
rriska	-0.0108 0.3308	-0.0050 0.6514	0.0563* 0.0000	0.0569* 0.0000	0.0096 0.3878	1.0000

\*significance at 0.05 level, n= 8144, rxpfood=weekly expenditure on food, rxphsdf=problem to pay for rent, rxphsd2=cutbacks in spending, rxphsd1=extra borrowing, rxphpdf=household burden, rriska=attitude towards taking risk.

The Spearman correlation is tested on sample of 8144 households with low income, representing consumers with absolute disadvantage. The Spearman correlation test found a very strong and positive relationship ( $r_s=0.9998$ ) between cutbacks in spending and need of extra borrowing. The need of additional credit is also correlated with food expenditures and cutbacks in spending. Although the relationship with the latter one seems to be weaker, it is still statistically significant. As discussed earlier when consumers experience a decrease in their disposable income, their consumption decreases but the decrease may not be proportional in the short-term due to habits leading to imperfect decisions. Taking additional credit due to financial problems that cannot be resolved by decreased consumption demonstrate the imperfect decision made by consumers with absolute disadvantage as additional pressure on their expenses leads to financial burden. Also a weaker, but still statistically significant relationship is found between food expenditure, problem to pay for rent and cutbacks in spending. The results suggest a statistically significant relationship between attitude towards taking risk and taking additional loan as well as problems with paying for the rent. Interestingly, no direct relationship has been identified between attitude towards taking the risk and household financial burden. This however does not rule out an indirect effect that will be investigated later.

### 2.3 Model

As previously discussed, Mayer's proposed relative advantage exploitation represents a situation where consumers after taking a payday loan experience a short-term (relative) improvement in their financial situation followed by long-term exploitation in form of rollovers or repeated loans. Due to mixed results from existing empirical evidence, this form of exploitation cannot be confirmed or rejected, leading to discrepancy in literature and limited effectiveness of government's policies tackling the problems with payday loans.

In contrast to Mayer's proposed form of relative advantage exploitation, conditional relative advantage exploitation introduced in this paper distinguishes between consumers with absolute disadvantage and consumers without absolute disadvantage. The rationale of distinguishing between these two groups is based on an assumption that relative advantage exploitation does occur, but its existence is conditional and experienced predominantly by consumers with absolute disadvantage. If the existence of conditional relative advantage exploitation can be confirmed, government's interventions towards avoiding situations where

consumers are exploited can be tailored to the exploited group and thus the effectiveness of interventions might be improved. Structural Equation Modelling (SEM), specifically path analysis, is used to evaluate the validity of assumptions proposed in previous section. The rationale of choosing path analysis, as the research tool is to examine the theory, since the structure of causal dependencies to be verified occurs only as a consequence of theory discussed in this paper. Path modelling is considered as a special case of SEM where structural relations among observed variables are modelled by measuring the direct and indirect interaction between variables and the degree to which certain variability is determined by individual causes. Structural relations represent hypotheses about directional influences as well as causal relations of multiple variables (Bollen, 1989, pp. 151–178). Path analysis is useful in making explicit the rationale of conventional regression calculations. It also has special usefulness in sociology problems involving the decomposition of a dependent variable or those in which successive experiences of a cohort are measured (Duncan, 1966).

Following diagram (Figure 12) represents proposed SEM model with path analysis where  $\gamma$  represents structural parameters relating exogenous variables to an endogenous variable and  $\beta$  stands for structural parameters relating endogenous variable to another endogenous variable. The causes of the relationship appear to the left of effects of the relationships. Two headed arrows indicate the non-causal associations between exogenous variables and unidirectional arrows represent causal associations from determining variable to its dependent variable. Unidirectional arrows leading from the residual variable to the dependent variable represent residuals.

**Figure 12** A path diagram revealing the determinants of conditional relative advantage exploitation

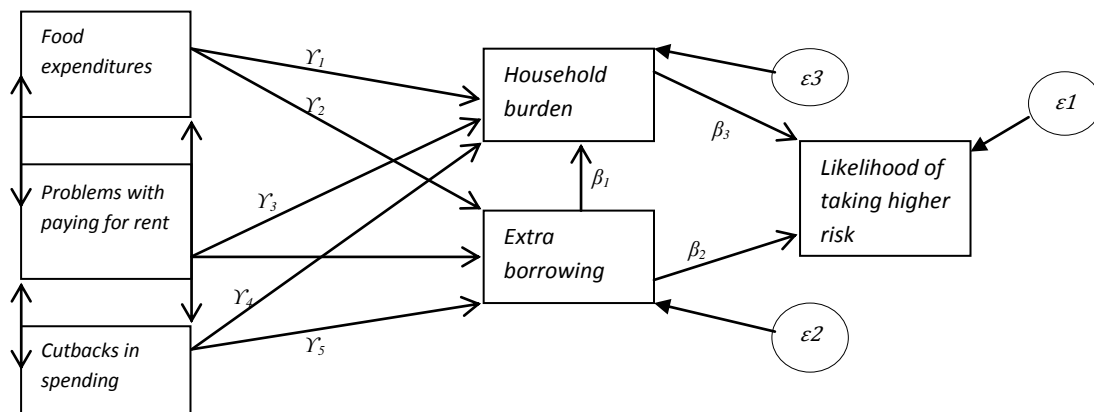

In the proposed model, food expenditures, problems with paying for rent and cutback in spending are exogenous variables, thus their variability is not explained by any variable in the model. Their variability is underpinned by economic factors, price trends and overall state of economy. Household burden, extra borrowing and likelihood of taking higher risk are endogenous variables whose variability is explained by one or more variables in the model. The proposed model represents assumptions that underpin existence of conditional relative advantage exploitation. The core assumption of conditional relative advantage exploitation is, that consumers with absolute disadvantage experience relative advantage exploitation. Proposed model therefore considers low-income households only.

Model assumes that exogenous factors such as weekly expenditure on food, problems with paying for rent and cutbacks in spending may directly contribute to household burden and due to limited income, also to the need of extra borrowing. Assumed non-casual association between exogenous variables suggests that these variables do not directly affect each other. Inclusion of the endogenous variables such as household burden, extra borrowing and

likelihood of taking higher risk represent assumption of Keynes' psychological law of consumption used in reversed situation. Thus it is assumed that decrease in available income leads to decrease in consumption but the decrease is not proportional in the short-term leading to imperfect decisions. Because consumption of consumers with absolute disadvantage is synonymous to basic needs, consumers have limited opportunities to compensate higher costs even in the short-term. This leads to forming imperfect decisions in the short-term when consumers with absolute disadvantage cannot adjust their habits to the lower level of available income. By this logic, consumers with absolute disadvantage act spontaneously, driven by the urge to solve their short-term discrepancy in income and expenses, without careful consideration of consequences in the long-term. However, due to inability to adjust their habits to the new, lower income in the long-term, they get trapped in rollovers and being exploited. Direct casual association represents this assumption when extra borrowing leads to households burden. The non-existence of savings jeopardizes the need of using additional credit but income of consumers with absolute disadvantage is below the UK's national average thus sources of extra credit are limited. It is assumed that extra credit cannot be provided in form of credit card, overdrafts or personal loan from a bank. It is assumed that additional borrowing might improve the financial situation of consumer with absolute disadvantage, but this relative improvement is only short-term and will in fact lead to household financial burden and willingness to take higher risk in the next period in order to resolve the financial difficulties.

### 3 Results and Discussion

The estimated path diagram is presented below in Figure 13. Detailed information on coefficient significance (Table A.1) and Goodness of fit tests (Table A.2) are presented in appendix.

Figure 13 Path Analysis – Conditional relative advantage exploitation

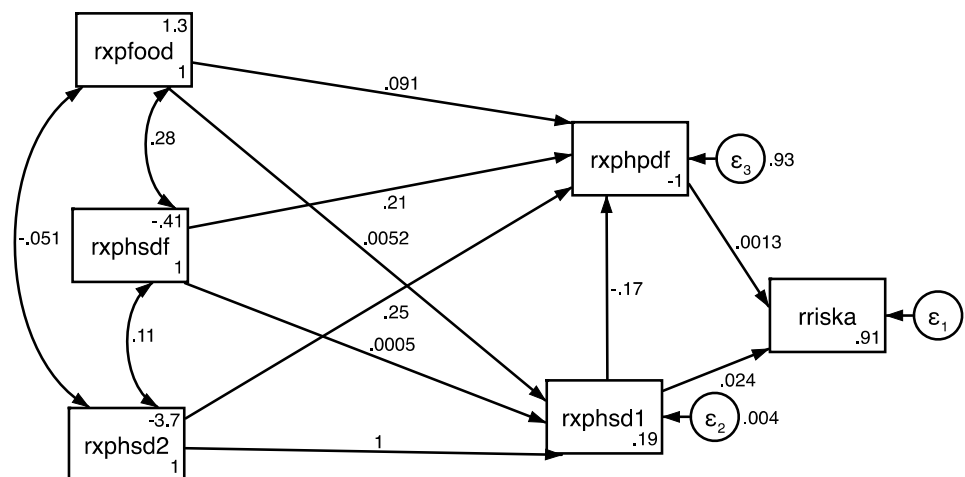

\*rxpfood - weekly expenditure on food, rxphsd1 - problem to pay for rent, rxphsd2 - cutbacks in spending, rxphpdf - household burden, rxphsd1 - extra borrowing, rxphsd2 - cutbacks in spending, rriska- likelihood of taking higher risk.

The path diagram shows that an increase in grocery expenditures and problems to keep up with rent payments are both positively correlated and create a pressure on households' budget. Food expenditures and rent are synonymous to basic needs thus options for cutbacks in the spending are very limited. Households therefore experience a gap between the income and expenditures that leads to worsening of their financial situation. Lack of savings and short-time period to adjust their spending to the new, lower, disposable income contribute to forming imperfect decisions explained by Keynes' as psychological law used in

reverse. Although increased food expenditures and problems paying for rent cause a substantial pressure on budget and need for extra borrowing these do not directly lead to household financial burden.

Due to low income, this group of households is very likely to be excluded from traditional forms of credit and represents consumers with absolute disadvantage. Payday loan is therefore the only option for additional credit. Result from path diagram shows that additional credit provides a short-term, relative improvement in the financial situation as it slightly decreases the household financial burden. Situation when absolutely disadvantage consumers experience improvement in their financial situation after taking additional credit can be described as earlier discussed Mayer's proposed sufficiency exploitation. However, in the next period, households experience increased costs due to repayment of a payday loan and unless another extra credit is provided, this situation inevitably leads to household financial burden spiral. This situation is unsustainable as existing pressure on households' budget to cover basic needs is jeopardized by additional cost in form of loan repayments. The result is in line with findings of cross-country employment outlook by OECD (2011) where findings show that a 20% decrease in disposable income in low-income households is associated with a significantly increased risk of financial burden.

As reported by Chetty and Szeidl (2007) increase in households' commitments create a pressure on budget and motivate to take a gamble due to difficulty to adjust their consumption. The results from the model confirm that additional loan and financial burden motivate households to risk preference. Households' willingness to take higher risk is in contrast with the "rational" behaviour proposed by neoclassical economics. In situation when income is limited and future expenditures are uncertain, households' willingness to take higher risk that could lead to worsening of their financial situation in the next period seems to be irrational. Irrational decision to resolve existing financial burden by engaging in risky decisions that inevitably lead to worsening their financial situation underpins the existence of exploitation. Although, households with absolute disadvantage have access to information on late repayment fees and high interest rates related to payday loan, they are more likely to take a risk and become voluntary exploited. Government's disclosure regulations on information provided by payday loan companies and cap on fees and interest rates introduced by Financial Conduct Authority (FCA) in 2014 might lead to lower level of financial burden of exposed households, but these cannot prevent them being voluntary exploited.

Increased likelihood of taking higher risk and being voluntary exploited is driven by spontaneous urge to action rather than inaction without careful consideration of consequences as described by Keynes' concept of animal spirit. Despite of awareness of higher risk and likelihood of making their financial situation worse, households' spontaneous urge to action is underpinned by unsustainable pressure on households' ability to cover financial commitments and is in fact an act in desperation. Situation that leads to this act in desperation is hardly underpinned by ability to process and compute information or level of financial education. Households are forced to make a survival decision when they are unable to cover basic needs (food and rent expenditures). The psychological distress in form of depression or anxiety they may experience as an outcome of unsustainable pressure might trigger the willingness to take a higher risk but it is not the main driver. Strong motivation to cover their survival needs is a heritage instinct of self-preservation that urges to action rather than inaction and due to exclusion from other forms of credit, households option for being voluntary exploited by payday loan companies. Although traditional economic theories might see action when individuals are voluntary exploited as irrational behaviour, for households with absolute disadvantage it is the only option and therefore their reasons for acting "irrationally" are perfectly rational.

Due to low-income and possible poverty, acting in desperation in order to cover survival needs is a persistent, in most cases a vicious cycle for consumers with absolute disadvantage explaining the reason why they get trapped in rollovers or repeated loans that

underpins the existence of relative advantage exploitation in this group. For consumers without absolute disadvantage, payday loan is faster and possibly more convenient, but not the only way, to cover for financial commitments. Higher level of income increases their ability to withdraw from payday loan, thus this group is more likely to experience sufficiency exploitation. Regulations imposed on payday loan providers might be effective in case of sufficiency exploitation when clear disclosure of late repayment fees and other options for extra credit increase awareness and motivate to more rational decisions and avoidance of the rollovers. However government regulations, in their current form, are powerless in case of consumers with absolute disadvantage as in this case the exploitation is their inevitable choice driven by survival instinct of action and exclusion from other forms of credit. It is a complex issue as business model of payday loan providers with 50 per cent of revenue from late repayment fees and rollovers is based on the existence of desperation. Although this business model is far away from being ethical, payday loan providers will be around as long as voluntary exploitation as an act in desperation is present. With low intergenerational earnings mobility and increasing number of households living in poverty, their business model is unlikely to fail. Providing a solution to voluntary exploitation is out of the scope of this paper, but it should be discussed to a certain level. Results suggest that problem could be resolved by eliminating the act in desperation that leads to voluntary exploitation or by creating another option for consumers with absolute disadvantage that would avoid exploitation. While it is rather impossible to eliminate the act in desperation, the latter solution might be more applicable. Due to higher risk related to consumers with absolute disadvantage, it is unlikely that any private business would be willing to provide credit without high interest rate that reflects higher risk. This might therefore require some degree of government involvement and possibly implementation of microcredit. Microcredit is a provision of small loans with low interest rate to the poor individuals (households with absolute disadvantage) and it is a component of microfinance often implied in countries with high poverty rate (Schreiner and Colombet, 2001). Although microcredit is usually used in poor rural areas to support small businesses or self-employed individuals, it has potential to become an alternative to payday loans. Implementation of microcredit for consumers with absolute disadvantage would provide additional option to payday loans and due to low interest rates, also contribute to lower financial burden. Since improvement in financial situation results in psychological benefits such as decrease depression (Rohe et al., 2016) microcredit might also eliminate the willingness to take a higher risk. It is important to note that there is mixed evidence on resolving the poverty problem by microcredit; this however does not limit its applicability in resolving the underpinning factors of voluntary exploitation.

## *Conclusion*

This paper contributes to the existing literature by identifying the underlining factors of exploitation. Based on survey sample of 8144 low-income British households, results indicate that in situation when income is limited and future expenditures are uncertain, households are more likely to take higher risk that could lead to worsening of their financial situation. Irrational decision to resolve existing financial burden by engaging in risky decisions that inevitably lead to worsening their financial situation underpins the existence of exploitation. Although, households with absolute disadvantage have access to information on late repayment fees and high interest rates related to payday loan, they are more likely to take a risk and become voluntarily exploited. Households are forced to make a survival decision when they are unable to cover basic needs (food and rent expenditures). The psychological distress in form of depression or anxiety they may experience as an outcome of unsustainable pressure might trigger the willingness to take a higher risk but it is not the main driver. Strong motivation to cover their survival needs urges to action rather than inaction and due to exclusion from other forms of credit, households option for being voluntarily exploited by payday loan companies. These results are significant as they provide empirical bias towards limited effectiveness of current regulations on payday loan lending tackling the problem of exploitation.

*References*

- Bentler, P., M. (1990). Comparative fit indexes in structural models. *Psychological Bulletin*, 107, 238–246. <https://doi.org/10.1037/0033-2909.107.2.238>
- Bernheim, B., D. (1986). Axiomatic Characterizations of Rational Choice in Strategic Environments. *The Scandinavian Journal of Economics*, 88(3), 473-488. <https://doi.org/10.2307/3440381>
- Bhaduri, A., Robinson, J. (1980). Accumulation and exploitation: an analysis in the tradition of Marx, Sraffa and Kalecki. *Cambridge Journal of Economics*, 4, 103-115.
- Blanden, J., Gregg, P., & Macmillan, L. (2007). Accounting for Intergenerational Income Persistence: Noncognitive Skills, Ability and Education. *Economic Journal*, 117, 43-60. <https://doi.org/10.1111/j.1468-0297.2007.02034.x>
- Bollen, K., A. (1989). *Structural Equations with Latent Variables*. New York: John Wiley & Sons, Inc. <https://doi.org/10.1002/9781118619179>
- Bridges, S., Disney, R. (2010). Debt and depression. *Journal of Health Economics*, 29(3), 388-403. <https://doi.org/10.1016/j.jhealeco.2010.02.003>
- British Household Panel Survey, (2012) GN33196 British Household Panel Survey, 1991-2009.
- Brown, S., Taylor, K. (2008). Household debt and financial assets: evidence from Germany, Great Britain and the USA. *Journal of the Royal Statistical Society: Series A (Statistics in Society)*, 171, 615–643. <https://doi.org/10.1111/j.1467-985X.2007.00531.x>
- Browne, M. W., Cudeck, R. (1993). *Alternative ways of assessing model fit*. Reprinted in *Testing Structural Equation Models*, ed. K. A. Bollen and J. S. Long, pp. 136–162. Newbury Park, CA: Sage.
- Browne, S., Taylor, K., & Wheatley, S. (2005). Debt and distress: evaluating the psychological cost of credit. *Journal of Economic Psychology*, 26 (5), 642-663. <https://doi.org/10.1016/j.joep.2005.01.002>
- Burgess, S., Gardiner, K., & Propper, C. (2001). Growing up: School, family and area influences on adolescents' later life chances. Centre for Analysis of Social Exclusion, London School of Economics: London.
- Burton, M. (2010). Keep the Plates Spinning: Perceptions of Payday Loans in Great Britain, London, Consumer Focus.
- Campbell, J. Y., Jackson, H. E., Madrian, B. C., & Tufano, P. (2011). Consumer Financial Protection. *Journal of Economic Perspectives*, 25 (1), 91-113. <https://doi.org/10.1257/jep.25.1.91>
- Carlson, M. J., Corcoran, M. E. (2001). Family Structure and Children's Behavioral and Cognitive Outcomes. *Journal of Marriage and the Family*, 63, 779-792. <https://doi.org/10.1111/j.1741-3737.2001.00779.x>
- Carneiro, P., Heckman, J., J. (2003). Human Capital Policy, IZA Discussion Papers 821, Institute for the Study of Labor (IZA). <https://doi.org/10.3386/w9495>
- Carneiro, P., Heckman, J. J. (2002). The Evidence on Credit Constraints in Post- secondary Schooling. *Economic Journal*, 112, 705-734. <https://doi.org/10.1111/1468-0297.00075>
- Conover, W., J. (1999). *Practical Nonparametric Statistics*. 3rd ed. New York: Wiley.
- Chetty, R., Szeidl, A. (2007). Consumption commitments and risk preferences. *The Quarterly Journal of Economics*, 122 (2), 831-877. <https://doi.org/10.1162/qjec.122.2.831>
- D'Addio, A. (2007). Intergenerational Transmission of Disadvantage: Mobility or Immobility Across Generations? A Review of the Evidence for OECD countries, OECD Social, Employment and Migration Working Papers, No. 52.

- Del-Rio, A., Young, G. (2005). The Impact of Unsecured Debt on Financial Distress Among British Households. Bank of England Working Paper Series No. 262. Bank of England. <http://dx.doi.org/10.2139/ssrn.824147>. Accessed 01 January 2017.
- Disney, R., Bridges, S., & Gathergood, J., (2008). Drivers of over-indebtedness: Report to the department for business, enterprise and regulatory reform. Centre for Policy Evaluation, University of Nottingham, Nottingham.
- Davidson, P. (1996). Reality and economic theory. *Journal of Post Keynesian Economics*, 18 (4), 479-508. <https://doi.org/10.1080/01603477.1996.11490083>
- Duncan, O., D. (1966). Path Analysis: Sociological Examples. *American Journal of Sociology*, 72 (1), 1-16. <https://doi.org/10.1086/224256>
- Edmonds, T. (2014). Payday loans: regulatory reform, House of Commons Briefing paper, No 06676, 4.
- Feinstein, L., (2000). The relative economic importance of academic, psychological and behavioural attributes developed in childhood. Centre for Economic Performance Discussion Paper, 443-447.
- Gov (2014). Payday lending market investigation. Regulation of payday lending. Gov. [https://assets.digital.cabinet-office.gov.uk/media/5329df81e5274a226b000293/140131\\_regulation\\_of\\_pdl\\_working\\_papers.pdf](https://assets.digital.cabinet-office.gov.uk/media/5329df81e5274a226b000293/140131_regulation_of_pdl_working_papers.pdf). Accessed 15 December 2016.
- Gregg, P. and Machin, S. (1998). Child Development and Success or Failure in the Youth Labour Market. Centre for Economic Performance, London School of Economics Discussion Paper 0397.
- Gregg, P., Macmillan, L., & Vittori, C. (2015). Nonlinear Estimation of Lifetime Intergenerational Economic Mobility and the Role of Education. DoQSS Working Papers 15-03, Department of Quantitative Social Science - UCL Institute of Education, University College London.
- Hammaker, D. (2010). *Health Care Management and the Law: Principles and Applications*. London: Cengage Learning.
- Keynes, J. M. (1936). *The General Theory of Employment. Interest and Money*. London: Macmillan.
- Keynes, J. M. (1937). The General Theory of Employment. *Quarterly Journal of Economics*, 51, 209-223. <https://doi.org/10.2307/1882087>
- Livingstone, S., Lunt, P. (1992). Predicting personal debt and debt repayment: psychological, social and economic determinants. *Journal of Economic Psychology*, 13, 111-134. [https://doi.org/10.1016/0167-4870\(92\)90055-C](https://doi.org/10.1016/0167-4870(92)90055-C)
- MacCallum, R. C., Browne, M. W., & Sugawara, H. M. (1996). Power analysis and determination of sample size for covariance structure modeling. *Psychological Methods*, 1, 130-149. <https://doi.org/10.1037/1082-989X.1.2.130>
- Marx, K. (1848). Collected Works. *The Manifesto of the Communist Party*, 6, 477-506.
- Mayer, R. (2003). Payday Loans and Exploitation. *Public Affairs Quarterly*, 17(3), 197-217.
- Malzer, B. T. (2011). The Real Costs of Credit Access: Evidence from the Payday Lending Market. *The Quarterly Journal of Economics*. 126 (1), 517-555. <https://doi.org/10.1093/qje/qjq009>
- McCarthy, Y. (2011). Behavioural characteristics and financial distress. European Central Bank, Working paper No.1303.
- Mishra, S., Fiddick, L. (2012). Beyond gains and losses: The effect of need on risky choice in framed decisions. *Journal of Personality and Social Psychology*, 102, 1136-1147. <https://doi.org/10.1037/a0027855>
- Morgan, D. P., Strain, M., R. (2008). Payday Holiday: How Households Fare After Payday Credit Bans. FRB of New York Staff Report No. 309. SSRN. <http://ssrn.com/abstract=1032621>. Accessed 03 September 2016. <https://doi.org/10.2139/ssrn.1032621>

- Morris, S. (1995). The Common Prior Assumption in Economic Theory. *Economics and Philosophy*, 11 (2), 227-253. <https://doi.org/10.1017/S0266267100003382>
- Morse, A. (2011). Payday Lenders: Heroes or Villains? *Journal of Financial Economics*, 102 (1), 28-44. <https://doi.org/10.1016/j.jfineco.2011.03.022>
- Muntaner, C., Eaton, W. W., & Diala, C. C. (2000). Social inequalities in mental health: A review of concepts and underlying assumptions. *Health*, 4 (1), 89–113. <https://doi.org/10.1177/136345930000400105>
- OECD (2011). *OECD Employment Outlook*. OECD Publishing, 161-165.
- ONS (2014). Regional Gross Disposable Household Income (GDHI): 2012, Office for National Statistics, Statistical Bulletin.
- ONS (2015). Persistent Poverty in the UK and EU, 2008-2013, ONS. [http://www.ons.gov.uk/ons/dcp171776\\_403629.pdf](http://www.ons.gov.uk/ons/dcp171776_403629.pdf). Accessed 18 August 2016.
- Pezza, L., K., Baumeister, R., F. (1996). Why do bad moods increase self-defeating behavior? Emotion, risk taking, and self-regulation. *Journal of Personality and Social Psychology*, 71 (6), 1250-1267. <https://doi.org/10.1037//0022-3514.71.6.1250>
- Rohe, M., W., Key, C., Grinstein-Weiss, M., Schreiner, M., & Sherraden, M. (2016). The Impacts of Individual Development Accounts, Assets, and Debt on Future Orientation and Psychological Depression. *Journal of Policy Practice*, DOI: 10.1080/15588742.2015.1125329
- Schreiner, M., Colombet, H., H. (2001). From Urban to Rural: Lessons for Microfinance from Argentina. *Development Policy Review*, 19 (3), 339–354. <https://doi.org/10.1111/1467-7679.00138>
- Simon, H. A. (1982). *Models of bounded rationality*. Cambridge: MIT Press.
- Stroukal, D. (2016). A longitudinal analysis of the effect of unemployment on health. *International Journal of Economic Sciences*, Vol. V92), pp.55-68. <https://doi.org/10.20472/ES.2016.5.2.004>
- Szilagyiova, S. (2015). The Effect of Payday Loans on Financial Distress in the UK. *Procedia Economics and Finance*, 30, 842-847. [https://doi.org/10.1016/S2212-5671\(15\)01334-9](https://doi.org/10.1016/S2212-5671(15)01334-9)
- Wright, E., O. (2005). *Approaches to class analysis*. Cambridge University Press: Cambridge. <https://doi.org/10.1017/CBO9780511488900>
- Wright, E., O. (1979). *Class Structure and Income Determination*. Academic: New York.

## Appendices

Table A.1 Estimated model

Standardized	OIM			
	Coef.	Std. Err.	[95% Conf.	Interval]
<b>Structural</b>				
<i>rxphsd1 &lt;-</i>				
rxpfood	0.0052338	0.0007349	<b>0.0037934*</b>	0.0066742
rxphsdf	0.0005007	0.0007362	<b>-0.0009422*</b>	0.0019437
rxphsd2	0.9981941	0.0001228	0.9979533	0.9984349
_cons	0.1914303	0.003071	0.1854112	0.1974494
<b>rxphpdf &lt;-</b>				
rxphsd1	-0.1687775	0.1687231	<b>-0.4994687*</b>	0.1619137
rxpfood	0.0914343	0.0111508	0.069579	0.1132895

rxphsdf	0.2059456	0.0109957	0.1843944	0.2274967
rxphsd2	0.2527859	0.1687521	<b>-0.0779622*</b>	0.5835339
_cons	-1.043178	0.0548554	-1.150692	-0.9356629
<i>rriska &lt;-</i>				
rxphsd1	0.0236258	0.0125244	<b>-0.0009215*</b>	0.0481732
rxphpdf	0.0012787	0.0125285	<b>-0.0232767*</b>	0.025834
_cons	0.9070145	0.0460901	0.8166796	0.9973495

\*Statistically significant coefficients,  $p < 0.01$  and  $p < 0.05$

Table A.2 Goodness of fit tests

Fit statistic	Value	Description
Likelihood ratio		
chi2_ms(3)	2.806	model vs. saturated
p > chi2	0.423	
chi2_bs(12)	45561.701	baseline vs. saturated
p > chi2	0.000	
Population error		
RMSEA	0.000	Root mean squared error of approximation
90% CI, lower bound	0.000	
upper bound	0.014	
pclose	1.000	Probability RMSEA $\leq$ 0.05
Baseline comparison		
CFI	1.000	Comparative fit index
TLI	1.000	Tucker-Lewis index
Size of residuals		
CD	0.996	Coefficient of determination

\*Chi-square test for estimated model compare to a saturated model suggests that estimated model has a better fit than saturated model ( $p = 0.423 > 0.05$ ). Also, baseline model fits significantly poorer than a saturated model ( $p = 0.000 < 0.05$ ). The data from estimated model are therefore consistent with a specified distribution, suggesting a good fit of the model. The Root Mean Square Error of Approximation (RMSEA) measures the fit of model based on the non-centrality parameter. MacCallum, Browne and Sugawara (1996) suggest using values 0.01, 0.05, and 0.08 to indicate excellent, good, and mediocre fit. For this model, RMSEA (0.000) reports an excellent fit of the model. Browne and Cudeck (1993) suggest a close fit of the model if the lower bound of the 90% confidence interval (CI) is below 0.05 and label the poor fit of the model if the upper bound is above 0.10. The confidence interval estimated for this model (90% CI) lower bound (0.000) below 0.05 and upper bound (0.014) lower than 0.10 also confirms a close fit of the estimated model. A one-sided test of the null hypothesis for RMSEA, p of close fit (PCLOSE), also indicates that the fit of the model is close p (1.000)  $> 0.05$ . Two indices, Comparative fit index (CFI) and Tucker-Lewis fit index (TLI), with value 1.000 indicate a good fit of the model (Bentler, 1990). Coefficient of determination (CD) being 0.996 also corresponds to a perfect fit of the model of  $CD = 1$ .